

## ADJUSTING THE PARAMETER VALUES

Note:  
Only modify these parameters if it is essential.

### ACCESSING PARAMETERS

Turn the thermostat off by pressing .

After turning the thermostat off, press .

Use  or  to adjust.

Press  to move to next menu.

Press  to store and exit.

#### 01. Temperature calibration for Zone 1

-1°C = decrease 1°C , 1°C = increase 1°C ...

#### 02. Temperature calibration for Zone 2

-1°C = decrease 1°C , 1°C = increase 1°C ...

#### 03. 5+2 / 7 Day Program Option (default 01)



01 = 5+2 Day Program, 02 = 7 Day Program

#### 04. Dual Options

01 set both zones as thermostats

02 set zone 1 as a thermostat and zone 2 as a timer

#### 05. Reset

This allows you to reset your thermostat to factory default.  
When your thermostat is turned off, press and hold  for about 5 seconds until you see Menu 05.  
Press and hold  until you see RES on screen.

## TECHNICAL INFORMATION

### SPECIFICATIONS

SUPPLY VOLTAGE	230-240 VAC
SWITCHING CAPABILITY	8A max for each zone
TEMP RANGE(A)	5°C-35°C
FLOOR SENSOR resistance default to 25°C	10 Kohm.
IP RATING	30
ORIENTATION	VERTICAL

## INSTALLATION

Carefully separate the front half of the thermostat from the back plate by placing a small flat head terminal driver into the slots on the bottom face of the thermostat.

Carefully unplug the cable connector which is plugged into the front half of the thermostat.

Place the thermostat front half somewhere safe.

Follow the Wiring Diagram to connect the floor heating cold leads, floor temperature sensor and electrical supply to the appropriate terminals.

Screw the thermostat back plate onto the flush box.

Re-connect the thermostat cable and clip the two halves back together.

## DIMENSIONS

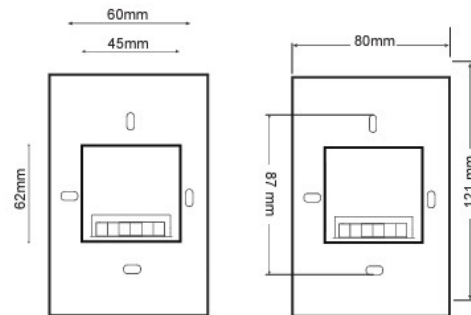

## WIRING DIAGRAM

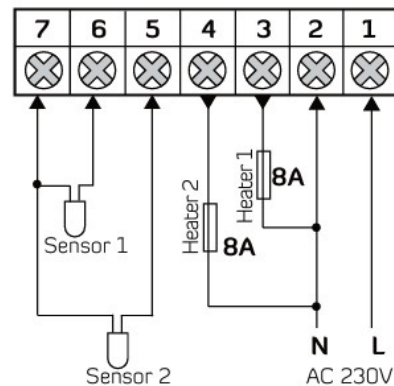

Note: Heater 1 refers to heating element in zone 1  
Heater 2 refers to heating element in zone 2  
Sensor 1 refers to sensor installed for zone 1  
Sensor 2 refers to sensor installed for zone 2

**COLDBUSTER**<sup>®</sup>  
*floor heating*

Affordable Luxury<sup>™</sup>

## Programmable Thermostat Coldbuster Dual



Large Touch Screen



Simple Programming



Accurate Control



5+2 / 7 Day Schedules



User-friendly Menu



2 Zones Programmable Heating

### Coldbuster Floor Heating

10/14 Rodborough Rd  
Frenchs Forest NSW 2086

Phone: +61 2 9982 5374 / Toll Free: 1800 85 75 65

Email: [sales@coldbuster.com.au](mailto:sales@coldbuster.com.au)

Website: [www.coldbuster.com.au](http://www.coldbuster.com.au)

1

## SETTING THE TIME AND DAY

Press , the time display will flash.

Use   to adjust.

Press  again, the day display will flash.

Use   to adjust.

Press  to store and exit.

## AUTO / MANUAL MODE



Press  to select Auto or Manual mode.

Auto mode:   
Manual mode: 

In Manual mode, press   to set the desired temperature.

In Auto mode, press   to override the current programmed temperature until the next programmed period.  will flash in this case.

## LOCKING THE KEYPAD

To lock the keypad, press and hold  for 5 seconds. You will see . To unlock, repeat the steps above and  will disappear.

## TEMPORARY OVERRIDE

In Auto mode, press   and the temperature display will flash.

Use   to adjust.













Press  to confirm.

 will flash on the screen.

Your thermostat will maintain the new setpoint until the next programmed period.

To cancel the override setting, press .

## LCD SYMBOLS

	power on / off
	mode button / menu button
	program button
	confirm the settings
	increase
	decrease
	auto mode
	manual mode
	flashing temporary override
	key lock symbol
	the heating is turned on
	the program numbers

## TURNING THE THERMOSTAT ON/OFF

Press  to turn on/off the thermostat. When your thermostat is turned off the LCD will display OFF. The outputs for all zones will be turned off.

## ALTERNATING THE ZONES



When your thermostat is turned on press and hold  for about 5 seconds to switch between zone 1 and zone 2.

2

## SETTING THE OPERATING SCHEDULES



For 5+2 day programmable mode (default)

### Default Settings

PROGRAM	MONDAY - FRIDAY				SATURDAY - SUNDAY			
	TIME	SETPOINT		TIME	SETPOINT			
		ZONE 1	ZONE 2		ZONE 1	ZONE 2		
	07: 00	22°C	22°C (ON)	07: 00	22°C	22°C (ON)		
	09: 30	16°C	16°C (OFF)	09: 30	16°C	16°C (OFF)		
	16: 30	22°C	22°C (ON)	16: 30	22°C	22°C (ON)		
	22: 30	16°C	16°C (OFF)	22: 30	16°C	16°C (OFF)		

### Changing programs for Monday-Friday



Press , the time for  (Program 1) will flash.

Use   to adjust the time for Program 1.

Press , the setpoint for Program 1 will flash.

Use   to adjust the setpoint for Program 1.

Press , the time for  (Program 2) will flash.

Use   to adjust the time for Program 2.

Press , the setpoint for Program 2 will flash.



Use   to adjust the setpoint for Program 2.

Repeat above steps for Program 3 and Program 4.

### Changing programs for Saturday-Sunday

When Monday-Friday programs have been set, continue

to press , the time for  (Program 1) will flash.

Use   to adjust the time for Program 1.

Press , the setpoint for Program 1 will flash.

Use   to adjust the setpoint for Program 1.

Press , the time for  (Program 2) will flash.



Use   to adjust the time for Program 2.

Press , the setpoint for Program 2 will flash.

Use   to adjust the setpoint for Program 2.

Repeat above steps for Program 3 and Program 4.





 Note:

For Saturday-Sunday, if you want to clear the time period of Program 2 and Program 3, Press  during programming. Press  again to cancel.

## SETTING THE OPERATING SCHEDULES



For 7 day programmable mode

### Default Settings



PROGRAM	MONDAY - SUNDAY			
	TIME	SETPOINT		
		ZONE 1	ZONE 2	
	07: 00	22°C	22°C (ON)	
	09: 30	16°C	16°C (OFF)	
	16: 30	22°C	22°C (ON)	
	22: 30	16°C	16°C (OFF)	

Press , the day display will start flashing.

Use   to select the day.

Press and hold  for about 5 seconds to select all 7 days of the week, and to cancel press and hold  for about 5 seconds again.

Press , the time for  (Program 1) will flash.

Use   to adjust the time for Program 1.

Press , the setpoint for Program 1 will flash.

Use   to adjust the setpoint for Program 1.

Press , the time for  (Program 2) will flash.



Use   to adjust the time for Program 2.

Press , the setpoint for Program 2 will flash.

Use   to adjust the setpoint for Program 2.

Repeat above steps for program 3 and Program 4.

 Note:

For Saturday-Sunday, if you want to clear the time period of Program 2 and Program 3, press  during programming. Press  again to cancel.