



## **Three Rail Vertical Floor Mount Heated Towel Warmers – Round Bars**

*Item #: HTW-3VFM*

### **Installation, Illustration, Cleaning & Safety Guidelines**

**Coldbuster Customer Service: 1800 85 75 65**

**WARNING:** Failure to read this guide prior to installing your COLD BUSTER heater(s) may result in installation problems that could void your heater warranty.



Vertical Floor Mount Heated Towel Rails will add a touch of class to any bathroom. Vertical rails come as a set of 3 and can be mounted in a straight line or staggered to provide a dramatic setting to compliment your free-standing bathtub.

The Vertical Floor Mount Heated Towel Rails are 700mm x 50mm; 800mm x 50mm and 1000mm x 50mm, made of high quality polished 304 stainless steel. Units operate at 53W (total) at 240V with concealed cable. Unit are SAA/CE certified and approved.

## Installation & Illustration

The layout pattern for your heated floor tubes is up to, whether you choose one of the layout options indicated in our installation guide or your own unique layout pattern to suit your bathroom.

Whichever layout pattern you choose, please be sure to discuss with your Builder, Tiler, Electrician and Trades Person as pre-planning and prep work will be required by all.

**Step 1:** Choose the layout best suited for your bathroom design. It would be beneficial to consult with your Builder, Tiler, Electrician or Trades Person to ensure the location you desire can be accommodated with electrical services and installation requirements.

**Step 2:** Arrange for your electrician to run conduit in the wall and to the floor area and the location of your heated floor tubes. This should be completed before any floor work or screeding is done as you will need to ensure access to the conduit and location or method for using the wire connection box or junction box. If screeding is already completed, you will need to arrange for chasing of the floor area for the wire connection box or junction box (100mm wide x 400mm length and depth of 45-50mm from bottom of tile) and the channel (25-30mm) for the 20mm conduit from the wall to the wire connection box or junction box in the floor area.

**Step 3:** Screeding can be completed for the floor area, however the conduit and location for the wire connection box or junction box should be left un-screeded. Leave area approx. 100mm wide by 400mm long as well as path 25-30mm wide for conduit to reach wire connection box or junction box. As indicated, you will need to locate wire connection box or junction box 45-50mm depth from where the bottom of tiles will be located.

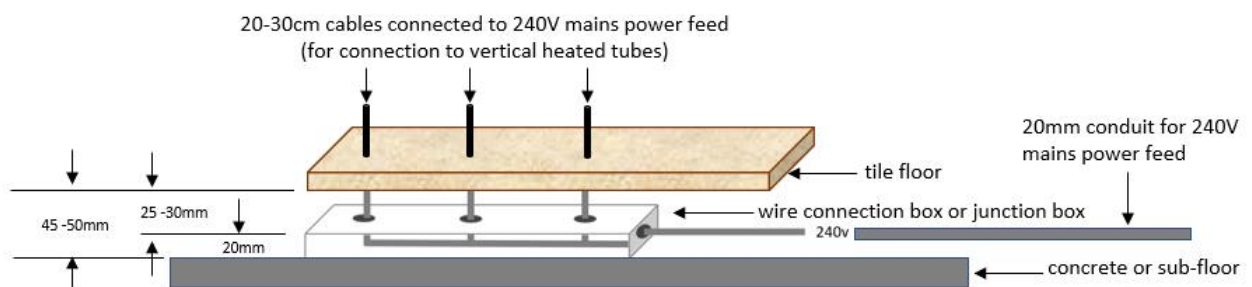

Fig. 1

**Step 4:** Electrician can now install wire connection box or junction box in the floor area, ensuring wire connection box or junction box is 25-30mm minimum below the tile level (bottom side). Run mains power cable to wire connection box or junction box positioned in the screed area.

Step 5: Electrician to prepare 3 cables (20-30cm each) to connect to mains power cable and thread up wire connection box or from junction box. These 3 cables will thread up through the holes pre-drilled in the tile where vertical mounted tubes will be located

**Step 6:** Installation process, your Tiler can complete the tile laying for the main floor area and for the tile/tiles where heated tubes are to be located. Tiles will require 3 holes (6mm dia.- refer to Fig.2) for mounting each floor tube as well as a hole in the centre (8mm - 10mm dia. – refer to Fig 1) of the mounting area where the electrical cord for each floor tube will feed up through the tiled floor from the wire connection box or junction box. Your Tiler can pre-drill all holes ready for floor tube installation. 12 holes in total will be required for installation area.

6L Plastic expanders (6mm) and ST5\*45 mounting screws have been provided with your floor tube purchase. Based on design and layout, these holes may be in 1 tile only making it easier to complete final installation. If over 2 or more tiles, you will need to ensure tiles have been pre-marked and pre-drilled where holes and mounting will be required.

Fig. 2 Tube mounting

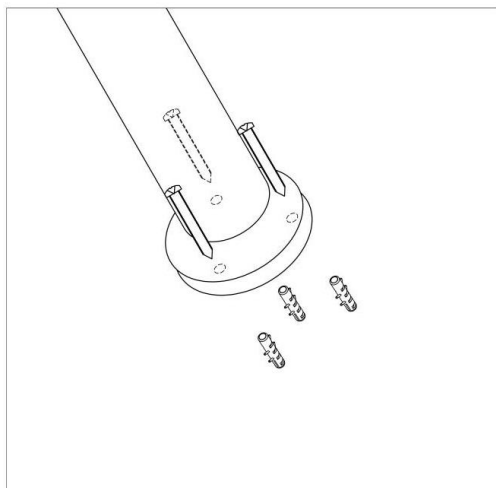
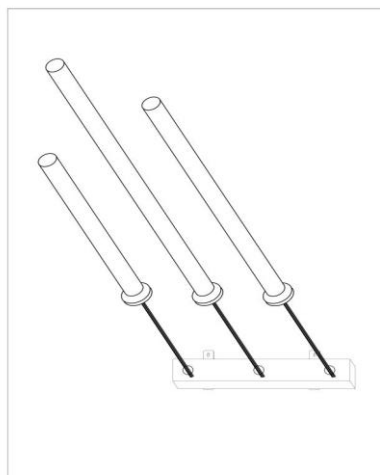

Fig. 3 Electrical tube heater cord



### Alternative Installation Process

**Step 1:** Alternative is to pre-mount floor heat tubes to the tile or tiles before they are laid. Feed electrical heat tube wires through the 3 centre holes of the mounting position pre-drilled in the tiles. Stove bolts, washers and hex nuts can be used to fix heated tubes to tiles (triangular pattern), ensuring you use sufficient length 6mm stove bolts, washers, and hex nuts to fix heated tubes securely and safely to the tile. Please note to safely cover stainless heat tubes with a soft covering to ensure heated tubes do not get marked or scratched during assembly and installation process. This process will allow for the fixed heated tubes and tile to be placed as 1 unit over the wire connecting box or junction box.

**Step 2:** Electrician will now be required to run cable through conduit to heated floor tube location. (do not connect to mains power at this time). Electrician can determine whether he will use wire connection box or an electrical junction box. Electrician to complete all wire connections.

**Step 3:** If area around wire connection box or junction box requires additional screed, lay tile and tubes gently and safely on their side and prepare underfloor area. Once screed has set or cured, tile with heated tubes can now be placed in appropriate position using adhesives to secure in place. If pre-mounted heat tubes are used, ensure wires are safely secured and are not pinched by tiles when lowered into place.

**Step 4:** Tiler can now complete any screed touch-up as required. Tiles or tile with heated tubes connected can now be placed in location with tile adhesives and grouting.

## Connection and On/Off Management

### Option 1:

Heated tubes are not thermostatically controlled and do not require a thermostat. However heated tubes can be operated by a Dual Thermostat that is managing underfloor heating. 1 part of the Dual thermostat will manage underfloor heating, using a floor sensor to sense actual floor temperature and can be managed by the thermostat (time and temperature). Temperature for floor heating will be controlled by the thermostat.

The 2<sup>nd</sup> part of the Dual Thermostat will operate as an on/off timer where the heated tubes can be connected. A timer will turn heated tubes on and off as programmed, however temperature is pre-set and not adjustable for the heated tubes.

This will require pre-planning with your Electrician or Builder to ensure mains power can be run to the required thermostat point as well as conduit and/or wiring cable. Wiring and cable will also need to be in place from the installed location of your heated tubes to the thermostat location.

### Option 2:

Heated tubes can be connected to a timer. Meaning tubes will start heating at the programmed time, turning off at the programmed time. Timer can be located on the wall next to a light switch or any convenient place that is accessible. This will require pre-planning with your Electrician or Builder to ensure mains power can be run to the required installation point or your heated tubes as well as conduit and/or wiring cable is in place to the timer location.

### Option 3:

Heated tubes can be connected to a dedicated standard light switch. Meaning tubes will start heating when switch is turned on and stop heating when switch is turned off. Light switch can be located in a convenient location within the room. This will require pre-planning with your Electrician or Builder to ensure mains power can be run to the required light switch location. Conduit and/or wiring cable will also need to be in place from the heated tube location to the light switch location.

## Cleaning

As the heating tubes and base flanges will require a wipe down from time to time, use only a soft damp cloth.

A mild detergent may be used if dirt and spots need to be removed. Gently wipe and rinse with soft damp cloth after use.

You can use a dry microfiber cloth to dry and polish heating tubes and base flanges.

NOTE: Do not use abrasive or corrosive cleaners on stainless heating tubes at any time.

## Safety Information

Please follow the basic safety instructions when using the electric heated towel rail products.

**READ THESE INSTRUCTIONS CAREFULLY.** Keep them handy for future reference.

- This appliance is used for warming and drying towels; therefore, it is hot to touch. Young children or infirm persons should be supervised when the product is working and ensure that they do not touch the appliance.
- The appliance will feel hotter to touch during warmer periods because of the rise in ambient temperature. Also, the insulation effect of towels will cause the operating temperature to increase slightly.
- The appliance should be installed so that switches and other controls cannot be touched by a person in the bath or shower.
- This appliance is ONLY used for warming and drying towels, DO NOT use it for any other purpose.

- To avoid danger this product **MUST NOT** be used to carry towels or any other articles that have been in contact with oil, petroleum-based products, or dry-cleaning fluids.
  - Make sure the voltage complies with the specification on the rating label, or elsewhere in these instructions.
  - **DO NOT** immerse in any liquid.
  - **DO NOT** allow the power cord to come in contact with the hot surface of the heating tubes when it is working.
  - If the product does not work well or is damaged, it must be fixed or replaced by the manufacturer, its service agent, or similarly qualified persons.
- **\*NOTE: Any electrical work must be carried out by a qualified licenced electrician.**

## Where Can Heated Towel Rails Be Installed?



Zone	requirements
Zone 0	Inside the bath or shower. Any Lighting used here must have a minimum rating of IP67 (protected against immersion in water)
Zone 1	Above the bath or shower to a height of 2.25m. A minimum rating of IP44 is required
Zone 2	The area stretching to 0.6m outside the bath or shower and above the bath or shower if over 2.25m. An IP rating of at least IP44 is required
Outside Zone	Anywhere outside zones 0, 1 & 2. Where water jets are not to be used for cleaning purposes, the general rules of BS7671 apply

**240V Heating Rails are safe for use in Zone 2 and the outside areas**